

- 3 Botón  de copia en color
- 4 Botón  de cancelar
- 5 Pulse los botones  de copia en ByN y  de copia en color al mismo tiempo para escanear.
- 6 Indicador  de papel
- 7 Indicador  de tinta

Tema principal: [Ubicación de los componentes del producto](#)

Componentes del producto - Parte superior

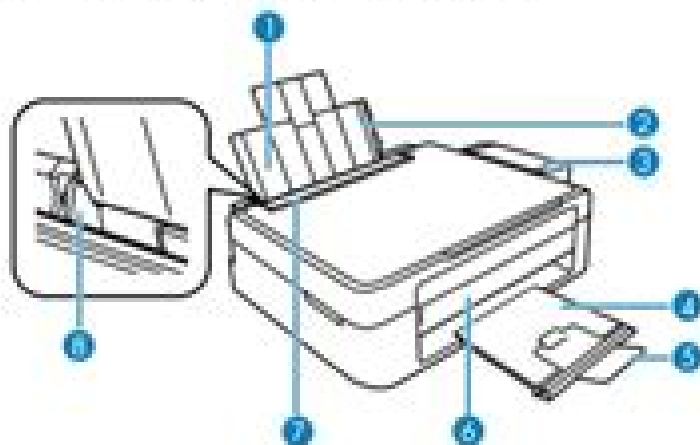

- 1 Alimentador de hojas
- 2 Soporte del papel
- 3 Unidad de tanques de tinta
- 4 Bandeja de salida del papel
- 5 Parador
- 6 Panel de control
- 7 Protector del alimentador

Epson Impresora Manual

S Ashworth



Epson Impresora Manual:

EPSON, MX Printer User's Manual, Type 3 and GRAFTRAX Plus David Alvin Lien,1982 **Epson** David Alvin Lien,1982

Epson ,1986 *Windows Manual de Referencia en Espanol* Ricardo Goldberger,2001-06-11 Este práctico y útil manual describe todas las características de uso y las innovaciones incorporadas en la última versión de este popular sistema operativo para computadores personales Efectivamente Windows Millennium o Windows Me como también se le conoce constituye un mejoramiento sustancial respecto de anteriores versiones ya que incluye en un entorno rico todas las herramientas necesarias para el trabajo en comunicaciones multimedia Internet fotografía y video digitales Una característica especial se refiere a la importancia que esta nueva versión de Windows concede a las interfaces gráficas y a Internet permitiendo su uso con notable facilidad Con un lenguaje claro e instrucciones paso a paso el texto también es complementado con gran cantidad de ilustraciones y esquemas El libro representa una valiosa herramienta para quienes ya están familiarizados con versiones anteriores de Windows y también para quienes se inician en el uso de un PC **Manual de actualización y reparación de PCs** Andy Rathbone,2000 *Microsoft Windows XP Manual Del Usuario* Nicolas Mazzola,2002 Este libro le permitirá conocer las principales innovaciones que introduce esta versión y al igual que el programa que trata se maneja gráficamente Por eso tendrá abundantes figuras para las cuales el texto servirá como complemento y explicación En términos generales se trata entonces de un Manual de Usuario ya que se desarrollan todas las posibilidades de Windows de uso más frecuente de menor a mayor complejidad Además se explican mediante guías visuales las principales pantallas y sus opciones se comentan paso a paso los procedimientos que el usuario deberá realizar y se presentan de manera esquemática las opciones avanzadas También se destacan las novedades de la versión XP y se hace hincapié en aquellos aspectos que cambiaron con respecto a las anteriores **Manual de Windows 98** Ricardo Goldberger,2000-10 La segunda edición actualizada y aumentada con las novedades de Windows 98 Segunda Edición de un manual indispensable que explica como dominar fácil y rápido todo lo referido al sistema operativo que sigue revolucionando al mundo Los temas incluidos van desde la instalación y el manejo práctico de la interfase hasta la navegación por Internet pasando por la configuración de dispositivos y programas utilización de las herramientas de mantenimiento y el programa de correo Outlook Express Además un desarrollo exhaustivo de los accesorios y herramientas del sistema información sobre el uso de Internet bajo Windows 98 y los componentes multimedia Este completo libro cubre de manera didáctica todo el sistema operativo y lo explica con prácticas guías visuales y explicaciones paso a paso En esta segunda edición se actualizó el diseño para hacerlo más ágil y práctico se agregaron servicios al lector y se incorporaron las novedades de Windows 98 Segunda Edición En el CD ROM se incluye el Windows 98 Second Edition para instalar en equipos que posean la versión registrada de Windows 98 Además podrán encontrar una sección de software que contiene una serie de utilitarios que realizan distintas funciones vinculadas con el sistema Archivos Turbo Browser 2000 7 0 Drag And File Gold 4 51 PowerDesk 4 0 Turbo Navigator 1 2 SmartDir 4 0 CopyTo 2 5 2Split 1 0

NameWiz 3 0 Compresores WinZip 8 0 PowerArchiver 2000 5 5 Squeez LE 3 0 NetZip 7 5 WinRAR 2 70 CuteZIP 1 1
PowerZip 5 01 PKZIP 2 70 TurboZIP 4 01 Escritorio DragStrip 3 7 Desktop Themes 1 87 WindowBlinds 1 3 QuickRun 3 0
Power Tray 5 01 IconCool 1 5 Optimizadores WindowBlinds WinMac Outsider LiteStep X Setup 5 6 TweakAll 1 1 ItweakU 3
10 OptiX 3 18 EasyMTU 3 0 Cacheman 3 60 RamBooster 1 4 TweakBIOS 1 53 Sistema SnagIt 5 0 InClip 1 02 24x7 Scheduler
2 0 StartStop 1 0 Audio Sliders 1 75 SelectEx 2000 **User's Manual for MX-100 Printer** David Alvin Lien,1982

UF0865 - Reparación de impresoras Francisco J. Pardo Muñoz,2015-05-20 La finalidad de esta Unidad Formativa es ense-
ar a identificar y solucionar aver as en impresoras y otros dispositivos perif ricos utilizando programas y tiles de ajuste
siguiendo las recomendaciones establecidas por los fabricantes Para ello se estudiar n las impresoras la manipulaci n y
sustituci n de elementos consumibles Tambi n se profundizar en la reparaci n de impresoras matriciales de inyecci n de tinta
y l ser **EPSON** ,1995 **MP3 Manual de Referencia** Gustavo Briozzo,2002-04 Sin duda una de las innovaciones m s
revolucionarias en el mundo de la computaci n en a os recientes se refiere al desarrollo de los formatos digitales para el
registro y reproducci n de sonido Y ciertamente MP3 ha llegado a convertirse en muy poco tiempo en el formato digital de
sonido preferido por la mayor cantidad de usuarios Este pr ctico y til manual contienen toda la informaci n necesaria para
tener un conocimiento acabado de este formato y as poder crear y escuchar archivos musicales Adem s este libro ense a c mo
compartir y obtener archivos MP3 desde el entorno de la red Tambi n contiene valiosa informaci n para reproducir archivos
MP3 y sugerencias para configurar modificar y crear nuevos Sainz con Winamp El libro ha sido escrito en un lenguaje claro
comprensible y menciona muchos ejemplos *Manual imprescindible de Office 97* Julián Casas Luengo,José Casas
Luengo,Francisco Paz González,1997-06-02 Manual para la realización de ruedas de negocios ,1989 Manual de la
Cámara Digital y Compacta Daniel Lezano,2001-03 Manual practico que orienta e informa sobre las camaras de ultima
generacion estudia los nuevos metodos digitales para el retoque y la manipulacion de la imagen fotografica y abarca las
tecnicas mas populares desde el paisaje o el retrato hasta la macrofotografia o trucos para lograr efectos especiales

Manual fundamental de Windows 98 Jaime Peña Tresancos, Ma. del Carmen Vidal,1998-09 UF0862 - Instalación y
configuración de periféricos microinformáticos Rafael Torres Llamas,2015-05-20 La finalidad de esta Unidad Formativa es
ense ar a instalar y configurar los perif ricos del equipo microinform tico para su explotaci n siguiendo especificaciones
establecidas seg n las necesidades de uso y en condiciones de seguridad Para ello se estudiar la descripci n de dispositivos
perif ricos y la instalaci n y prueba de perif ricos **Epson Action Printer 5000** EUA). EPSON AMERICA
INCORPORATION (Torrance,1991 **EPSON** ,1995 EPSON ,1995 Epson Stylus color 300 ,1997

Embark on a breathtaking journey through nature and adventure with Crafted by is mesmerizing ebook, Natureis Adventure: **Epson Impresora Manual** . This immersive experience, available for download in a PDF format (*), transports you to the heart of natural marvels and thrilling escapades. Download now and let the adventure begin!

<https://equityfwd2024.radcampaign.com/data/browse/Documents/John%20Wilkinson%201728%201808%20English%20Ironmaster%20And%20Inventor%20Studies%20In%20British%20History.pdf>

Table of Contents Epson Impresora Manual

1. Understanding the eBook Epson Impresora Manual
 - The Rise of Digital Reading Epson Impresora Manual
 - Advantages of eBooks Over Traditional Books
2. Identifying Epson Impresora Manual
 - Exploring Different Genres
 - Considering Fiction vs. Non-Fiction
 - Determining Your Reading Goals
3. Choosing the Right eBook Platform
 - Popular eBook Platforms
 - Features to Look for in an Epson Impresora Manual
 - User-Friendly Interface
4. Exploring eBook Recommendations from Epson Impresora Manual
 - Personalized Recommendations
 - Epson Impresora Manual User Reviews and Ratings
 - Epson Impresora Manual and Bestseller Lists
5. Accessing Epson Impresora Manual Free and Paid eBooks
 - Epson Impresora Manual Public Domain eBooks
 - Epson Impresora Manual eBook Subscription Services
 - Epson Impresora Manual Budget-Friendly Options

6. Navigating Epson Impresora Manual eBook Formats
 - ePub, PDF, MOBI, and More
 - Epson Impresora Manual Compatibility with Devices
 - Epson Impresora Manual Enhanced eBook Features
7. Enhancing Your Reading Experience
 - Adjustable Fonts and Text Sizes of Epson Impresora Manual
 - Highlighting and Note-Taking Epson Impresora Manual
 - Interactive Elements Epson Impresora Manual
8. Staying Engaged with Epson Impresora Manual
 - Joining Online Reading Communities
 - Participating in Virtual Book Clubs
 - Following Authors and Publishers Epson Impresora Manual
9. Balancing eBooks and Physical Books Epson Impresora Manual
 - Benefits of a Digital Library
 - Creating a Diverse Reading Collection Epson Impresora Manual
10. Overcoming Reading Challenges
 - Dealing with Digital Eye Strain
 - Minimizing Distractions
 - Managing Screen Time
11. Cultivating a Reading Routine Epson Impresora Manual
 - Setting Reading Goals Epson Impresora Manual
 - Carving Out Dedicated Reading Time
12. Sourcing Reliable Information of Epson Impresora Manual
 - Fact-Checking eBook Content of Epson Impresora Manual
 - Distinguishing Credible Sources
13. Promoting Lifelong Learning
 - Utilizing eBooks for Skill Development
 - Exploring Educational eBooks
14. Embracing eBook Trends
 - Integration of Multimedia Elements

- Interactive and Gamified eBooks

Epson Impresora Manual Introduction

In this digital age, the convenience of accessing information at our fingertips has become a necessity. Whether its research papers, eBooks, or user manuals, PDF files have become the preferred format for sharing and reading documents. However, the cost associated with purchasing PDF files can sometimes be a barrier for many individuals and organizations. Thankfully, there are numerous websites and platforms that allow users to download free PDF files legally. In this article, we will explore some of the best platforms to download free PDFs. One of the most popular platforms to download free PDF files is Project Gutenberg. This online library offers over 60,000 free eBooks that are in the public domain. From classic literature to historical documents, Project Gutenberg provides a wide range of PDF files that can be downloaded and enjoyed on various devices. The website is user-friendly and allows users to search for specific titles or browse through different categories. Another reliable platform for downloading Epson Impresora Manual free PDF files is Open Library. With its vast collection of over 1 million eBooks, Open Library has something for every reader. The website offers a seamless experience by providing options to borrow or download PDF files. Users simply need to create a free account to access this treasure trove of knowledge. Open Library also allows users to contribute by uploading and sharing their own PDF files, making it a collaborative platform for book enthusiasts. For those interested in academic resources, there are websites dedicated to providing free PDFs of research papers and scientific articles. One such website is Academia.edu, which allows researchers and scholars to share their work with a global audience. Users can download PDF files of research papers, theses, and dissertations covering a wide range of subjects. Academia.edu also provides a platform for discussions and networking within the academic community. When it comes to downloading Epson Impresora Manual free PDF files of magazines, brochures, and catalogs, Issuu is a popular choice. This digital publishing platform hosts a vast collection of publications from around the world. Users can search for specific titles or explore various categories and genres. Issuu offers a seamless reading experience with its user-friendly interface and allows users to download PDF files for offline reading. Apart from dedicated platforms, search engines also play a crucial role in finding free PDF files. Google, for instance, has an advanced search feature that allows users to filter results by file type. By specifying the file type as "PDF," users can find websites that offer free PDF downloads on a specific topic. While downloading Epson Impresora Manual free PDF files is convenient, its important to note that copyright laws must be respected. Always ensure that the PDF files you download are legally available for free. Many authors and publishers voluntarily provide free PDF versions of their work, but its essential to be cautious and verify the authenticity of the source before downloading Epson Impresora Manual. In conclusion, the internet offers numerous platforms and websites that allow users to download free PDF files legally. Whether its classic literature, research

papers, or magazines, there is something for everyone. The platforms mentioned in this article, such as Project Gutenberg, Open Library, Academia.edu, and Issuu, provide access to a vast collection of PDF files. However, users should always be cautious and verify the legality of the source before downloading Epson Impresora Manual any PDF files. With these platforms, the world of PDF downloads is just a click away.

FAQs About Epson Impresora Manual Books

What is a Epson Impresora Manual PDF? A PDF (Portable Document Format) is a file format developed by Adobe that preserves the layout and formatting of a document, regardless of the software, hardware, or operating system used to view or print it. **How do I create a Epson Impresora Manual PDF?** There are several ways to create a PDF: Use software like Adobe Acrobat, Microsoft Word, or Google Docs, which often have built-in PDF creation tools. Print to PDF: Many applications and operating systems have a "Print to PDF" option that allows you to save a document as a PDF file instead of printing it on paper. Online converters: There are various online tools that can convert different file types to PDF. **How do I edit a Epson Impresora Manual PDF?** Editing a PDF can be done with software like Adobe Acrobat, which allows direct editing of text, images, and other elements within the PDF. Some free tools, like PDFescape or Smallpdf, also offer basic editing capabilities. **How do I convert a Epson Impresora Manual PDF to another file format?** There are multiple ways to convert a PDF to another format: Use online converters like Smallpdf, Zamzar, or Adobe Acrobats export feature to convert PDFs to formats like Word, Excel, JPEG, etc. Software like Adobe Acrobat, Microsoft Word, or other PDF editors may have options to export or save PDFs in different formats. **How do I password-protect a Epson Impresora Manual PDF?** Most PDF editing software allows you to add password protection. In Adobe Acrobat, for instance, you can go to "File" -> "Properties" -> "Security" to set a password to restrict access or editing capabilities. Are there any free alternatives to Adobe Acrobat for working with PDFs? Yes, there are many free alternatives for working with PDFs, such as: LibreOffice: Offers PDF editing features. PDFsam: Allows splitting, merging, and editing PDFs. Foxit Reader: Provides basic PDF viewing and editing capabilities. How do I compress a PDF file? You can use online tools like Smallpdf, ILovePDF, or desktop software like Adobe Acrobat to compress PDF files without significant quality loss. Compression reduces the file size, making it easier to share and download. Can I fill out forms in a PDF file? Yes, most PDF viewers/editors like Adobe Acrobat, Preview (on Mac), or various online tools allow you to fill out forms in PDF files by selecting text fields and entering information. Are there any restrictions when working with PDFs? Some PDFs might have restrictions set by their creator, such as password protection, editing restrictions, or print restrictions. Breaking these restrictions might require specific software or tools, which may or may not be legal depending on the circumstances and local laws.

Find Epson Impresora Manual :

john wilkinson 1728-1808 english ironmaster and inventor studies in british history

[journal of glass studies; vol. 34](#)

josef originals figurines of muriel joseph george

[joseph lowerys beyond dreamweaver isbn 0735712778](#)

johnny caronte zombie detective the revolver

johnny&39;s farm.

[jouer avec le feu](#)

[jonathan livingston fliegle](#)

[joint disease in the horse](#)

journal of a living experiment

[jordan investment and business guide](#)

joseph andrews 61 hm pb

[josephine and me](#)

[jonathan park and the secret of the hidden cave](#)

[joseph smith a prophet an historical novel prayer with a promise](#)

Epson Impresora Manual :

Test Bank for Campbell Essential Biology with ... Feb 4, 2023 — Sell ? Test Bank for Campbell Essential Biology with Physiology 5th Edition Simon Chapter 1 - 29 Updated 2023 \$19.99 Add to cart. test bank for campbell essential biology ... - Knoowy Sep 2, 2023 — TEST BANK FOR CAMPBELL ESSENTIAL BIOLOGY WITH PHYSIOLOGY, 5TH EDITION BY SIMON, DICKEY, REECE, HOGAN · Preview document (3 of 367 pages) · Knoowy ... Test bank Campbell Essential Biology with Physiology, 5th ... Mar 29, 2023 — Test bank Campbell Essential Biology with Physiology, 5th Edition, Simon ISBN-9780321967671. Course; CAMPBELL ESSENTIAL BIOLOGY WITH PHYSIOLOGY, ... Campbell Essential Biology 5th Edition Simon Test Bank 1 Campbell Essential Biology 5th Edition Simon Test Bank 1 - Free download as PDF File (.pdf), Text File (.txt) or read online for free. Test Bank. Test Bank For Campbell Essential Biology 5th Edition By ... Test Bank For Campbell Essential Biology 5th Edition By Simon Pdf Pdf. INTRODUCTION Test Bank For Campbell Essential Biology 5th Edition By Simon Pdf Pdf ... Test Bank for Biology, Campbell and Reece, 5th Edition Book details · Print length. 688 pages · Language. English · Publisher. Addison Wesley · Publication date. January 1, 1999 · ISBN-10. 0805365613 · ISBN-13. 978- ...

Campbell Essential Biology With Physiology Global 5th ... Campbell Essential Biology With Physiology Global 5th Edition
Simon Test Bank - Free download as PDF File (.pdf), Text File (.txt) or read online for free. Pin on Study Guides for textbooks
Complete downloadable Solutions Manual for Campbell Essential Biology 5th Edition by Simon. ... Test Bank for Economics
Canada in the Global Environment 7th ... Campbell Biology Test Bank Test Bank for Campbell Biology Ninth Edition
[Paperback] Paperback - January 1, 2011. by Louise Paquin · 3.03.0 out of 5 stars (1). Campbell Essential Biology with
Physiology, 5th Edition ... Feb 9, 2023 — Below are summaries, lecture notes, study guides and practice exams for Campbell
Essential Biology with Physiology, 5th Edition Test Bank of ... Bobbin Winding Preparations - Pfaff Creative 1471 ... Pfaff
Creative 1471 Manual Online: Bobbin Winding Preparations. I have a pfaff creative 1471. The machine won't disengage so
Aug 21, 2021 — Hi, I have a pfaff creative 1471. The machine won't disengage so that I can wind the bobbin? Contractor's
Assistant: Do you know the model ... Pfaff 1471 Troubleshooting For Winding Bobbins Pdf Page 1. Pfaff 1471 Troubleshooting
For Winding Bobbins Pdf. INTRODUCTION Pfaff 1471 Troubleshooting For Winding Bobbins Pdf FREE. Pfaff 1471 loose
bobbin thread : r/sewing Try holding onto the original spool of thread to hold back some thread while it's winding onto the
bobbin. Also don't wind too fast or too ... Bobbin Winder - Pfaff 1471 E1 Instruction Manual [Page 106] With the bobbin
winder on, the bobbin winder spindle must engage reliably. With the. bobbin winder off, the friction wheel 5 must not engage
the drive wheel ... SOLVED: My Pfaff 1471 keeps spinning when I'm winding Jul 7, 2019 — To disengage the needle while
winding a bobbin do the following: the handwheel on the right end of the machine has an inner knob. hold the outer ... Ebook
free Set theory an intuitive approach solutions lin (... Oct 7, 2023 — a thorough introduction to group theory this highly
problem oriented book goes deeply into the subject to provide a fuller understanding ... Set Theory An Intuitive Approach
Solutions Lin (2023) Oct 3, 2023 — A topological solution to object segmentation and ... Set Theory An Intuitive Approach
Solutions Lin Book Review: Unveiling the Power of Words. 2IIM CAT Preparation - Intuitive Method to Solve Set Theory Set
Theory An Intuitive Approach Solution If you ally obsession such a referred set theory an intuitive approach solution ebook
that will have the funds for you worth, acquire the unconditionally ... Intuitive and/or philosophical explanation for set theory
... Jun 18, 2010 — We define something by quantifying over a set that contains the thing being defined. The intuition is that if
we avoid such "impredicative" ... Solved My question is Set Theory related. Recently we were Sep 27, 2019 — The methods to
be used to prove the identities/relationships is through set builder notation or set identities. Specifically 3c seems intuitive, ...
Books by Shwu-Yeng T. Lin Looking for books by Shwu-Yeng T. Lin? See all books authored by Shwu-Yeng T. Lin, including
Set Theory With Applications, and Set theory: An intuitive ... Chapter 2 An Intuitive Approach to Groups One of the major
topics of this course is groups. The area of mathematics that is con- cerned with groups is called group theory. Loosely
speaking, group ... Measure Theory for Beginners: An Intuitive Approach Theorem 1: There exist sets in the reals which are
non-measurable. That is, no matter how I define a measure, there is no way to give a definite ...